

风扇 / FAN

KM12038S-S2502-C



产品参数 / Product Parameters

机框 / Frame: Die-cast Aluminum Alloy

扇叶 / Impeller: PBT of UL94V-0.

接线方式 / Connection: Terminal Plug

重量 / Weight: 490g

外观尺寸 / Dimensions

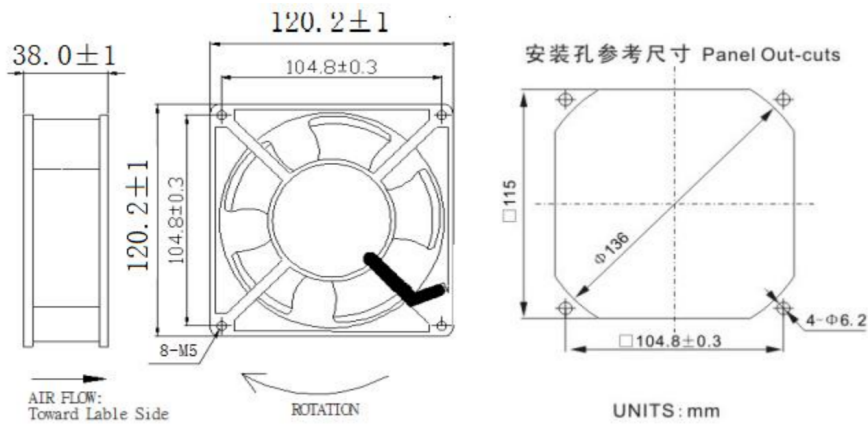

技术数据 / Technical Data

型号 Model	额定电压 Rated Voltage	电压范围 Voltage Range	启动电压 Starting Voltage	额定电流 Rated Current	额定功率 Rated Power	额定转速 Rated Speed	额定风量 Rated Airflow	额定静压 Rated Static Pressure	噪音 Noise Level
	V	V	V	A	W	rpm	cfm	mmH2O	dB(A)
KM12038S-S2502-C	230VAC 50/60Hz	220~240VAC 50/60Hz	184VDC	0.13/0.11 ±10%	20/18 ±10%	2500/2800 ±10%	84/96	7.5/7.8	43/47

轴承类型 Bearing system	保存温度范围 Storage Temperature Range	保存湿度范围 Storage Humidity Range	工作温度范围 Operating Temperature Range	工作湿度范围 Operating Humidity Range	寿命 Life Expectancy [MTTF]
Dual Ball Bearing	-30°C ~ 70°C	0% ~ 95%RH	-20°C ~ 70°C	0% ~ 95%RH	60'000H [25°C]

曲线图 / Curves

